

SYNCHROPRINT 5000

THE ULTIMATE CHOICE FOR YOU AS A PROFESSIONAL SCREEN PRINTER!

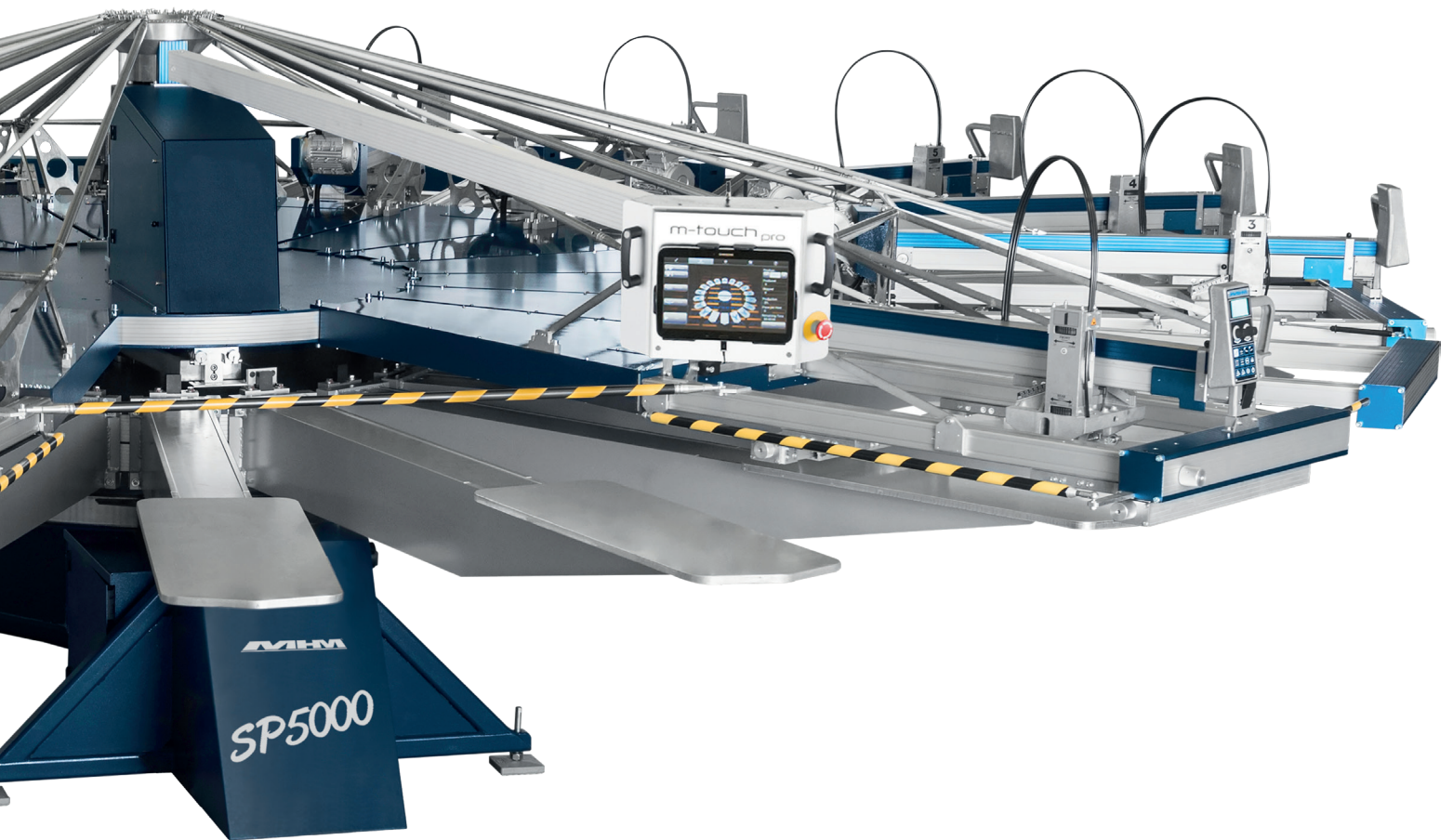

- + Adjustable screen holders for various frame sizes**
 - > Simple use of different screen lock systems
- + Centralised off-contact adjustment**
 - > Easy control via tablet
- + Super-rigid pallet support arms**
 - > Zero deflection and thereby a very good print result
- + Individual off-contact adjustment on all stations**
 - > Off-contact can be set separately for each station > maximum flexibility
- + Vacuum-pallet-system (optional)**
 - > Perfect for graphic-, foil- and paper printing
- + Automatic ,GOTO' registration system with job memory (optional)**
 - > Shorter setup-times



SYNCHROPRINT 5000



Specifications (all models)

Air pressure (minimum)	8 bar / 116 psi (filtered, dry air supply only)
Drive system	AC-Servo drive indexer / electrical squeegee drive
Electrical supply	3 ph ~210 / 400 V, 50 / 60 Hz (+/- 5 %)
Electrical requirement (indexer)	2.5 kW
Electrical requirement (per print station)	0.4 kW (manual) / 0.6 kW (GoTo)
Registration accuracy	+/- 0.02 mm / +/- 0.00079"
Rec. frame profile	4 x 4 cm / 1.57 x 1.57"
Max. frame size 50 x 70 cm / 19.7 x 27.6"	75 x 112 cm / 29.5 x 44.1"
Max. frame size 70 x 100 cm / 27.6 x 39.4"	91 x 144 cm / 35.8 x 56.7"
Max. frame size 80 x 110 cm / 31.5 x 43.3"	105 x 154 cm / 41.3 x 60.6"
Max. production capacity	900 - 1,400 pcs/h (acc. to model)

Specifications (per model)

	SP5000-08	SP5000-10	SP5000-12	SP5000-14	SP5000-16	SP5000-18	SP5000-20
Number of pallets	8	10	12	14	16	18	20
Max. number of print stations	6	8	10	12	14	16	18
Max. diameter 50 x 70 cm / 19.7 x 27.6"	505 cm / 199"	505 cm / 199"	555 cm / 219"	600 cm / 236"	640 cm / 252"	690 cm / 272"	735 cm / 289"
Max. diameter 70 x 100 cm / 27.6 x 39.4"	575 cm / 226"	625 cm / 246"	685 cm / 270"	735 cm / 289"	n/A	n/A	n/A
Max. diameter 80 x 110 cm / 31.5 x 43.3"	635 cm / 250"	675 cm / 266"	740 cm / 291"	n/A	n/A	n/A	n/A
Machine height	187 cm / 73.5 "						205 cm / 80.7 "
Machine weight (kg / lbs)	2.100 / 4,630	2.300 / 5,070	2.550 / 5,620	2.740 / 6,040	3.150 / 6,950	3.640 / 8,030	3.890 / 8,580
Average air consumption (l/min)	190 (6.7 cfm)	220 (7.7 cfm)	250 (8.8 cfm)	280 (9.9 cfm)	310 (10.9 cfm)	340 (12.0 cfm)	370 (13.1 cfm)
Rec. capacity of air supply (l/min)	500 (17.7 cfm)	550 (19.4 cfm)		600 (21.2 cfm)	650 (23 cfm)		700 (24.7 cfm)

